



# basic education

Department:  
Basic Education  
**REPUBLIC OF SOUTH AFRICA**

**NATIONAL  
SENIOR CERTIFICATE**

**GRADE 12**

**CIVIL TECHNOLOGY: WOODWORKING**

**NOVEMBER 2023**

**MARKING GUIDELINES**

**MARKS: 200**

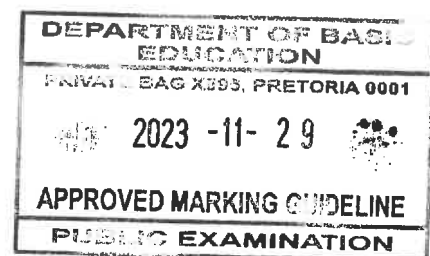

**These marking guidelines consist of 21 pages.**

MR. PJ BOOYSEN  
EXT. MOD  
UMALUSI

MR. NP SIMONS  
EXT. MOD  
UMALUSI

MR. I BORCHERS  
INT. MOD  
DBE

MS. L GEYER  
INT. MOD  
DBE

**INSTRUCTIONS FOR MARKERS****1. Markers should:**

- Familiarise themselves with the question and answer before evaluating the responses of candidates.
- Always interpret the responses of the candidates within the context of the question.
- Consider any relevant and acceptable answer during pre-marking but should strictly adhere to the answers after finalisation of the marking guideline.
- There are TWO approaches to answering questions; these are (1) to describe and (2) to explain.
  - If a candidate is required to explain e.g., a process in 4 steps, only the first 4 responses should be considered.
  - However, if for example candidate is required to explain or describe a process, we need to consider that that candidates may write a long description, not necessarily well organised. In this case the marker needs to evaluate the complete statement to judge if the candidate explained the required outcome satisfactorily and allocate marks on merit.
- Mark what the candidate wrote and do not interpret or predict responses.
- Indicate the tick or cross right at the position where the mark needs to be awarded or where the candidate made the error.
- Accept the letter corresponding with the correct answer as well as the answer written in full in multiple-choice questions or similar questions.
- Accept incorrect spelling in one-word answers unless the spelling changes the meaning of the answer.
- If a learner writes two or more answers separated by a slash (/) mark only the first response, unless the additional answer/s are different names for the same item e.g., Yale lock/Night latch. In this case, the answer for the response should be awarded and the slash (/) should NOT be considered as an additional answer.

**2. For calculations:**

- A mark is only awarded if the correct unit is written next to the answer. If the question states that the answer must be in a specific unit, a mark will ONLY be awarded if the answer has the correct unit as indicated in the question.
- Marks will only be allocated for the correct values if the candidates add instead of multiply. NO marks will be awarded for the calculations and the answer.
- Where an incorrect answer is correctly carried over, the marker must recalculate the values, using the incorrect answer from the first calculation. If correctly used, the candidate should receive the full marks for subsequent calculations.

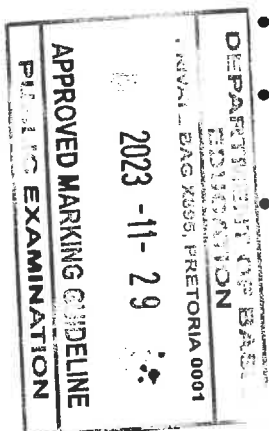

- Alternative methods of calculations must be considered, provided that the correct answer is obtained.
- For the calculation of quantities marks will be awarded for the correct use of the dimension paper.

### 3. When marking drawings:

- The member for which the mark should be awarded should be drawn correctly in the correct position to receive a mark.
- A member incorrectly drawn but wrongfully repeated in another position will be awarded the mark for the repeated incorrect member provided that the marking guideline provide for TWO or more marks for that member (positive marking).
- Marks can only be awarded for a label if the label is correctly indicating the correct member.
- Scale drawings should always be marked using an appropriate mask.
- If the incorrect/wrong drawing was drawn, the candidate can be awarded for only what was provided for on the marking guideline.
- If a line diagram or an orthographic view instead of a pictorial drawing (isometric/oblique/perspective) is drawn, the first assessment criteria for each member will be marked wrong, but marks will be awarded for the subsequent members if TWO or more marks are awarded for the same member.
- If candidates draw/give more information than what is required, mark strictly according to the assessment criteria.

### 4. Incorrect numbering of questions:

- If a candidate numbered an incorrectly, but the answer is in the correct position according to the sequence of the questions in the question paper, circle then the incorrect numbering and mark the response.
- If questions were answered randomly not following the same sequence as in the question paper and the learner numbered incorrectly, the response should NOT be marked.

### 5. Duplication of responses and questions answered in the correct place:

- If a question has been answered twice, mark the first response.
- If a question should be answered on an answer sheet and the candidate answered it on both the answer sheet and in the answer book, mark the response on the answer sheet and cancel the response in the answer book.

If the question has been answered in the answer book instead of on the answer sheet, mark the response in the answer book according to the assessment criteria on the marking guideline.

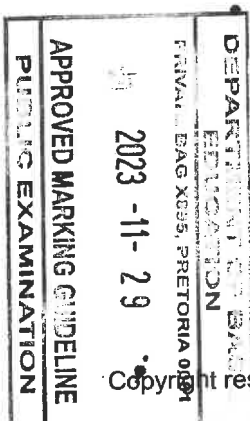

Copyright reserved



Please turn over

**QUESTION 1: OHSA, MATERIALS, TOOLS, EQUIPMENT AND JOINING  
(GENERIC)**

- |       |        |   |     |
|-------|--------|---|-----|
| 1.1   | 1.1.1  | B ✓   | (1) |
|       | 1.1.2  | B ✓   | (1) |
|       | 1.1.3  | D ✓   | (1) |
|       | 1.1.4  | D ✓   | (1) |
|       | 1.1.5  | C ✓   | (1) |
|       | 1.1.6  | C ✓   | (1) |
|       | 1.1.7  | A ✓   | (1) |
|       | 1.1.8  | A ✓   | (1) |
|       | 1.1.9  | D ✓   | (1) |
|       | 1.1.10 | C ✓   | (1) |
|       | 1.1.11 | B ✓   | (1) |
|       | 1.1.12 | A ✓   | (1) |
| 1.2.1 | 1.2.1  | Rawlbolt/Coach screw with a plug/Threaded rod/Bolt and nut/<br>Plastic plug with a screw ✓  | (1) |
|       | 1.2.2  | Raw bolt/Coach screw with a plug/Threaded rod/Bolt and nut/<br>Plastic plug with a screw:<br><ul style="list-style-type: none"> <li>• Are strong fasteners ✓</li> <li>• Resists pull out failure ✓</li> <li>• Have excellent mechanical properties</li> <li>• Have excellent carrying capacity/Ability/Carry heavy weight</li> <li>• Are suitable for tensile strength and yield stress</li> <li>• Are suitable for variance of hole sizes</li> </ul> <b>ANY TWO OF THE ABOVE</b> | (2) |

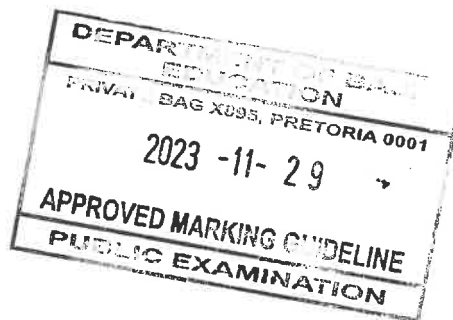

1.2.3

- Drill holes into the pier and remove the debris. ✓
- Remove bolts and washers and insert shields into holes. ✓
- Insert bolts with washers through the hinges and tighten. ✓

OR

- Drill holes into the pier and remove the debris.
- Insert plastic plugs into the holes.
- Insert rawl bolts/coach screws with plugs/threaded rods/bolts/plastic plugs with screws through the hinges and tighten.

OR

- Drill holes through the pier and remove the debris.
- Insert the threaded rod/bolt into the hole and add the nuts.
- Tighten the nuts. (3)

1.3

- The circuit board of the laser level can be damaged. ✓
- Moisture can damage the laser level.
- The laser level might not function properly.

**ANY ONE OF THE ABOVE**

(1)

1.4

- Perform regular collimation tests on the dumpy level. ✓
- Calibrate the dumpy level regularly.

**ANY ONE OF THE ABOVE**

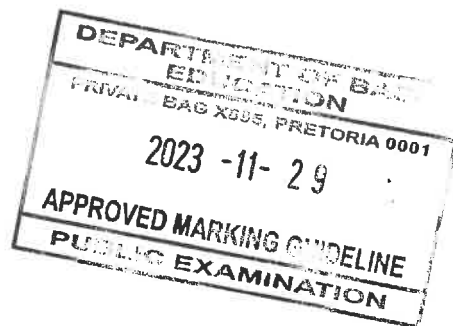

(1)

[20]



**QUESTION 2: GRAPHICS AS MEANS OF COMMUNICATION (GENERIC)**

NO.	QUESTIONS	ANSWERS	MARKS
1.	Give ONE reason why FIGURE B represents the first floor plan.	Window next to sliding door/patio door on balcony/Staircase arrows pointing upwards/Arrows on staircase ✓	1
2.	Name the SI unit that is used to indicate dimensions on building plans.	Millimetre/mm ✓	1
3.	Identify number 1.	Sliding door/Patio door ✓	1
4.	Identify the number indicating the emergency exit.	2 ✓	1
5.	What is the purpose of number 3?	To support the handrails/To fill the spaces between the posts/For aesthetic purposes/To prevent people from falling off the balcony/For safety purposes ✓	1
6.	Identify number 4.	Window sill/Sill ✓	1
7.	Identify number 5.	Gutter ✓	1
8.	Identify number 6.	Downpipe/Rainwater pipe/Rainwater downpipe/RWDP ✓	1
9.	Identify number 7.	Balcony/Cantilever balcony/Balcony slab /Concrete slab ✓	1
10.	Deduce from the window schedule the dimensions of the window that is installed at number 8.	900 mm ✓ x 600 mm ✓ OR 0,9 m x 0,6 m	2
11.	Who is the owner of the new dwelling?	Mr Ntombi ✓	1
12.	Name the elevation where the sink is located.	East elevation/East ✓	1
13.	Identify the safety error in FIGURE A.	No balusters/rails/safety rails on balcony ✓	1
14.	Deduce from the building plan why it was not approved after the first submission.	Drawing of internal staircase/ Internal staircase was omitted ✓	1

15.	Name the material that must be used for the balusters.	Aluminium ✓	1
16.	Deduce from the notes column the type of roof illustrated in FIGURE A.	Lean-to-roof ✓	1
17.	How many signatures must be indicated on this building plan?	2 ✓	1
18.	What are the dimensions for the balusters as indicated by the architect?	Ø 50 mm ✓ x 1 200 mm ✓	2
19.	Name the material that must be used for the final finishing of the outside wall.	Plaster and paint/Plaster/Paint ✓	1
20.	Describe the end shape of the balustrades.	Round/Circular/Circle/Cylindrical ✓	1
21.	How many hinged openings are indicated on Window 1 in the window schedule?	3 ✓	1
22.	Draw the symbol for finished wood for the boardroom table.	 ✓	2
23.	Draw the electrical symbol for a three-pole one-way switch.	 ✓	2
24.	How many fluorescent tubes are indicated in the office?	2 ✓	1

25.	Calculate the total height of the wall on the left side of the building from the finished floor level. Give your answer in meter.	$2,955 \checkmark + 2,955 \checkmark + 3,0 \checkmark$ $= 8,91 \checkmark \text{ m}$ <p>OR</p> $2\ 955 + 2\ 955 + 3\ 000$ $= 8,91 \text{ m}$	4
26.	Calculate the area of the exterior wall on the ground floor, that will consist of bricks, from the finished floor level to the top of the floor slab in the south elevation in FIGURE A. Show ALL calculations.	$(2,955 \checkmark \times 8,0 \checkmark) - (2,4 \checkmark \times 1,2 \checkmark)$ $= 23,64 \checkmark - 2,88 \checkmark$ $= 20,76 \checkmark \text{ m}^2 \checkmark$ <p>OR</p> $(2\ 955 \times 8\ 000) - (2\ 400 \times 1\ 200)$ $= 23\ 640\ 000 - 2\ 880\ 000$ $= 20\ 760\ 000 \text{ mm}^2$	8
		<b>TOTAL:</b>	<b>40</b>

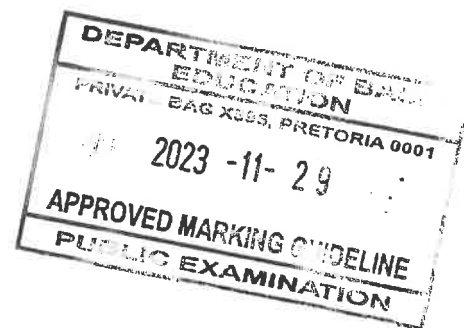



**QUESTION 3: CUPBOARDS, CASEMENTS, WALL-PANELLING AND QUANTITIES (SPECIFIC)**

3.1

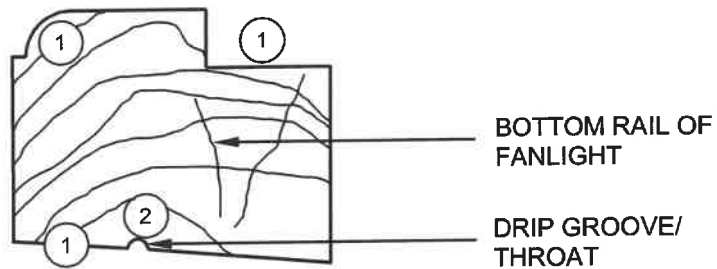

NO.	ASSESSMENT CRITERIA	MARK
1	Bottom rail of fanlight:	
	Rebate	1
	Moulded edge	1
	Bottom part of fanlight angled	1
2	Drip groove/Throat	1
	<b>TOTAL:</b>	<b>4</b>

(4)

3.2

A	B	C	D
3.2.1			<b>Internal dimension</b>
			7 000 – 2/220 ✓ = 6 560 mm ✓ OR
			7 000 – 440 = 6 560 mm
			<b>Total length of wall plate needed</b>
2/ ✓	6,56 ✓	13,12 ✓ m	13,12 m of wall plate needed
3.2.2			<b>Total length of timber required for the king posts</b>
			Length of a king post is 870 mm
8/ ✓	0,87 ✓	6,96 ✓ m	6,96 m total length needed
			Correct use of dimension paper. ✓

(2)

(3)

(3)

(1)

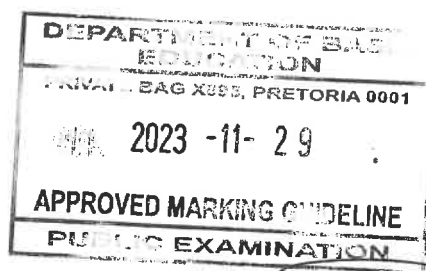

3.3

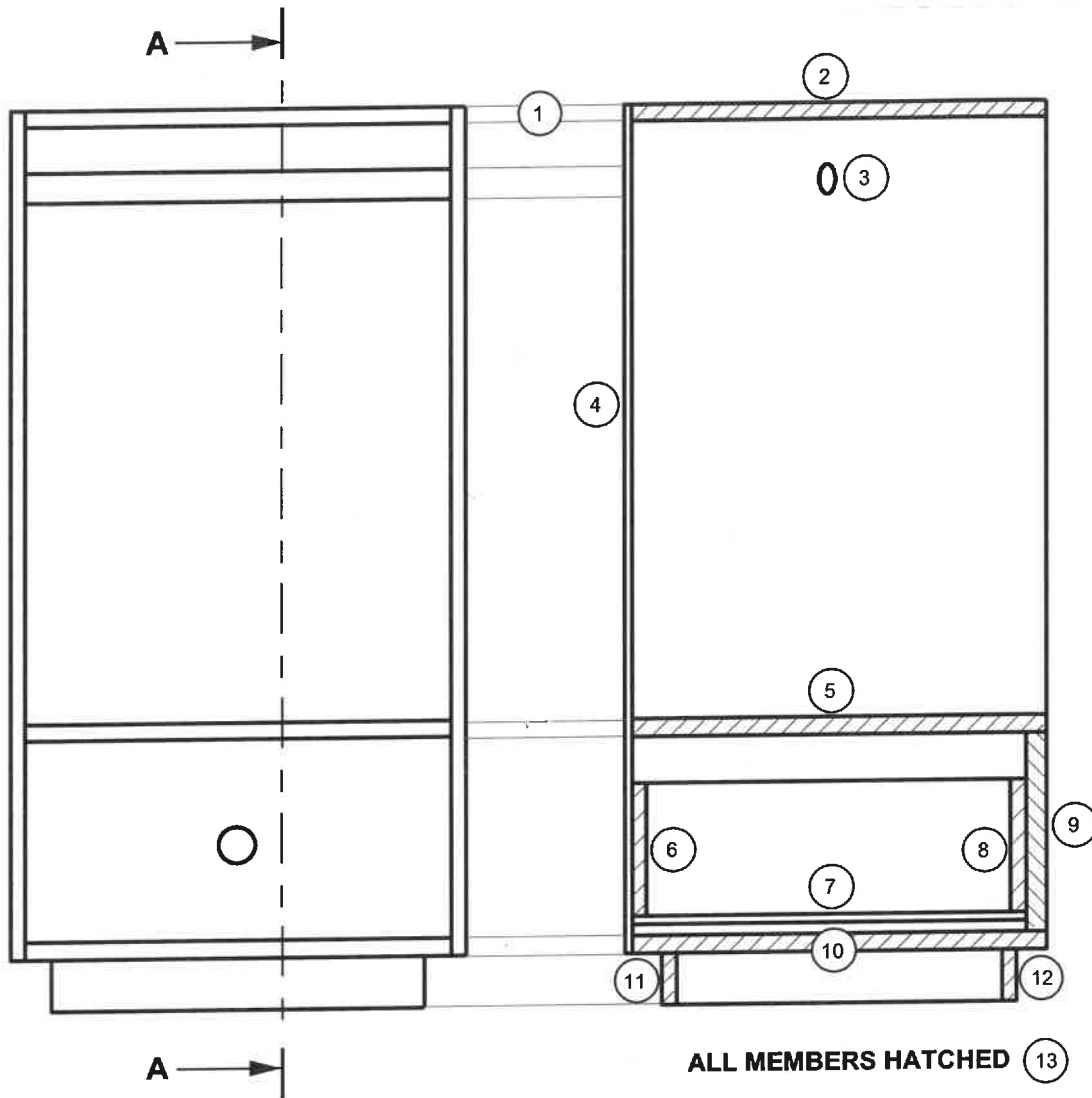

NO.	ASSESSMENT CRITERIA	MARK
1	Projection (Lines must be indicated)	1
2	Top of top unit	1
3	Oval hanging rail	1
4	Back (Thinner than melamine boards)	1
5	Bottom/Shelf	1
6	Drawer back	1
7	Drawer bottom (Thinner than melamine boards)	1
8	Drawer front	1
9	Front	1
10	Bottom of unit	1
11	Back of base	1
12	Kick plate	1
13	All members correctly hatched	1
<b>TOTAL:</b>		<b>13</b>

(13)

DEPARTMENT OF BASIC EDUCATION  
 PRETORIA  
 2023 -11- 29  
 APPROVED MARKING GUIDELINE  
 PRACTICE EXAMINATION

3.4

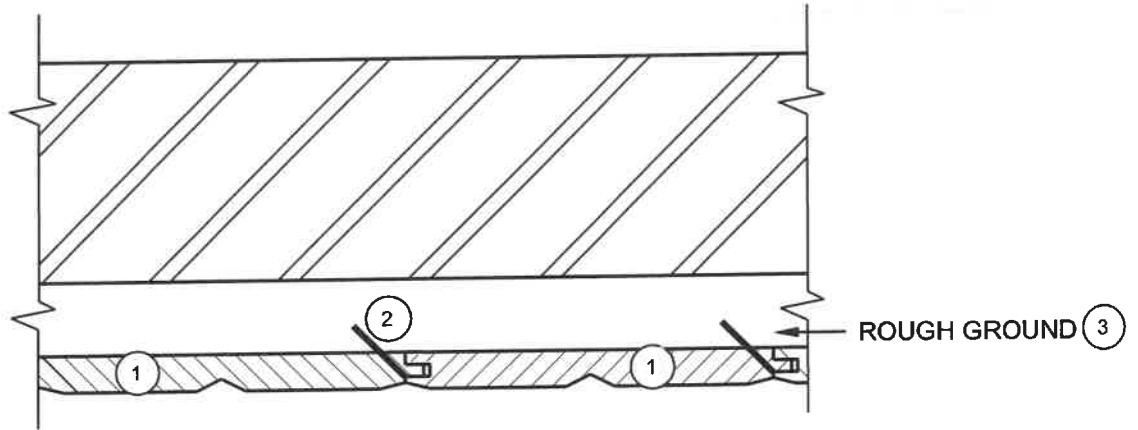

NO.	ASSESSMENT CRITERIA	MARK
1	Tongue-and-groove boards (At least two)	2
2	Panel pin at correct position (Only one)	1
3	Label of horizontal rough ground (Correctly indicated)	1
<b>TOTAL:</b>		<b>4</b>

(4)  
[30]

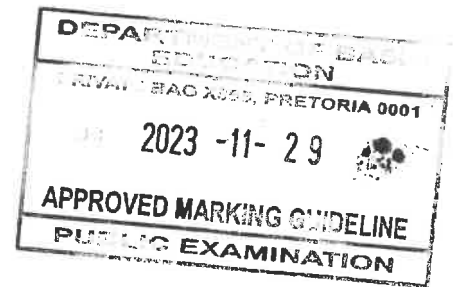

*(Handwritten initials)*

*(Handwritten signature)*

**QUESTION 4: ROOFS, CEILINGS, TOOLS, EQUIPMENT AND MATERIALS  
(SPECIFIC)**

- |     |       |   |     |
|-----|-------|---|-----|
| 4.1 | 4.1.1 | C ✓   | (1) |
|     | 4.1.2 | G ✓   | (1) |
|     | 4.1.3 | E ✓   | (1) |
|     | 4.1.4 | B ✓   | (1) |
|     | 4.1.5 | H ✓   | (1) |
| 4.2 | 4.2.1 | grain ✓   | (1) |
|     | 4.2.2 | red/cinnamon red ✓  | (1) |
|     | 4.2.3 | width ✓   | (1) |
|     | 4.2.4 | moisture ✓  | (1) |
|     | 4.2.5 | operate ✓   | (1) |
| 4.3 | 4.3.1 | A trapdoor is valuable because it allows access to: <ul style="list-style-type: none"> <li>• The roof space ✓</li> <li>• The geyser in the roof space</li> <li>• The wiring in the roof space</li> <li>• The plumbing in the roof space</li> <li>• The storage space</li> <li>• Do maintenance</li> </ul> <b>ANY ONE OF THE ABOVE</b> | (1) |
|     | 4.3.2 | 38 mm x 38 mm ✓   | (1) |

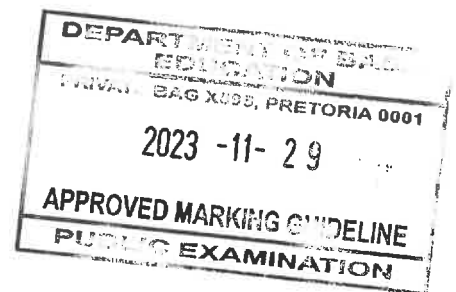

4.3.3

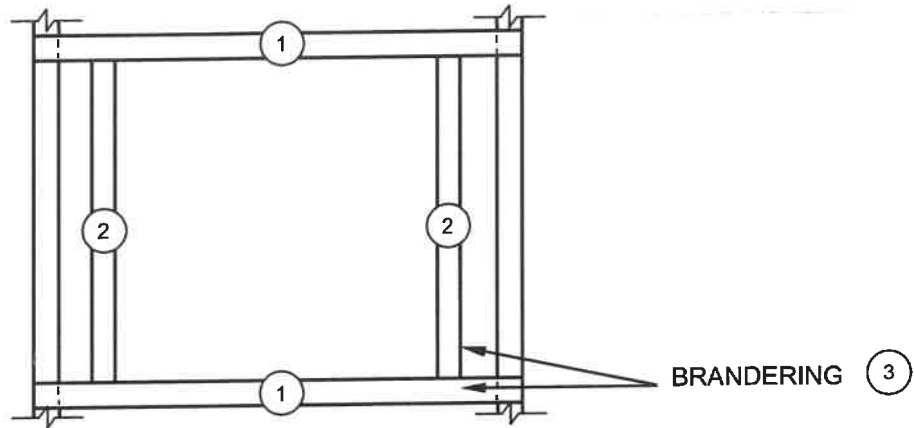

NO.	ASSESSMENT CRITERIA	MARK
1	Brandering (Horizontal)	2
2	Brandering (Vertical)	2
3	Any ONE label	1
<b>TOTAL:</b>		<b>5</b>

(5)

4.4 Installing roof sheeting:

- Place the first sheet in position ✓
- Ensure that it is straight and square ✓
- Drill the holes for the roofing screws/nails through the crests of the sheet ✓
- Nail or screw the sheet to the purlins ✓

(4)

4.5 Truss hangers:

Truss hangers are used to attach TWO members like beams to walls and/or other members to each other at different angles. ✓

Gang nails:

Gang nails can be used to join TWO or more members like roof truss members in the same plane. ✓

(2)

4.6

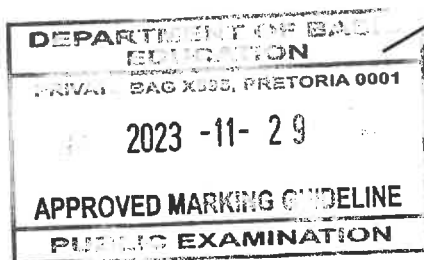
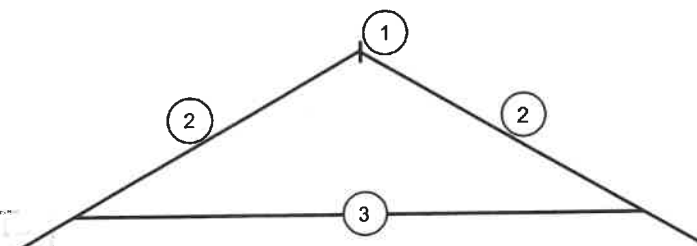

NO.	ASSESSMENT CRITERIA	MARK
1	Ridge beam	1
2	Rafters	2
3	Tie beam	1
<b>TOTAL:</b>		<b>4</b>

(4)

- 4.7 4.7.1 IBR/Inverted box rib ✓ (1)
- 4.7.2 Roof sheeting used in coastal areas:  
Are exposed to extreme weather conditions and moisture ✓ and  
needs to be protected against corrosion. ✓ (2)
- 4.7.3 Storing of sheets before installation:  
  - Sheets must be raised above the ground ✓
  - Sheets must be well ventilated/kept dry**ANY ONE OF THE ABOVE** (1)
- 4.8 Spacing = 450 ✓ – 75 ✓  
= 375 mm ✓ (3)
- 4.9 Design of roof trusses:  
  - Be sturdy/strong enough to carry the load of the roof covering ✓
  - Materials must be strong enough ✓
  - Be able to withstand wind and other forces/Durable
  - Provide adequate height in any room immediately below the roof and ceiling assembly
  - Should not allow the accumulation of rainwater upon the roof surface
  - Be neat and solid to enhance the appearance of the building**ANY TWO OF THE ABOVE** (2)
- 4.10 4.10.1 Sanding can be done in any direction. ✓ (1)
- 4.10.2
  - To avoid contact with the sanding pad ✓
  - To prevent damage to the cord**ANY ONE OF THE ABOVE** (1)
- 4.10.3 The sanding dust will clog the sandpaper if not removed. ✓ (1)
- 4.10.4
  - The clogged sandpaper will leave marks on the wood ✓
  - Marks will be left on the wood
  - Wood will be damaged
  - Sanding will not be effective**ANY ONE OF THE ABOVE** (1)

[40]

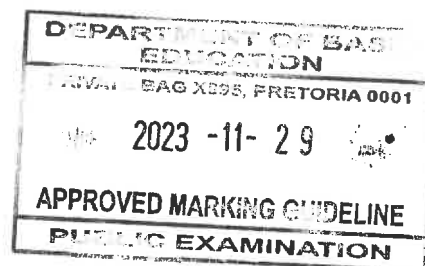

**QUESTION 5: CENTERING, FORMWORK, SHORING AND GRAPHICS AS MEANS OF COMMUNICATION (SPECIFIC)**

- 5.1      5.1.1      Dead shore ✓ (1)
- 5.1.2      Double flying shore/Flying shore ✓ (1)
- 5.2      Materials for needles:
  - Steel/Metal ✓
  - Timber/Wood**ANY ONE OF THE ABOVE** (1)
- 5.3      Steel dogs ✓ (1)
- 5.4

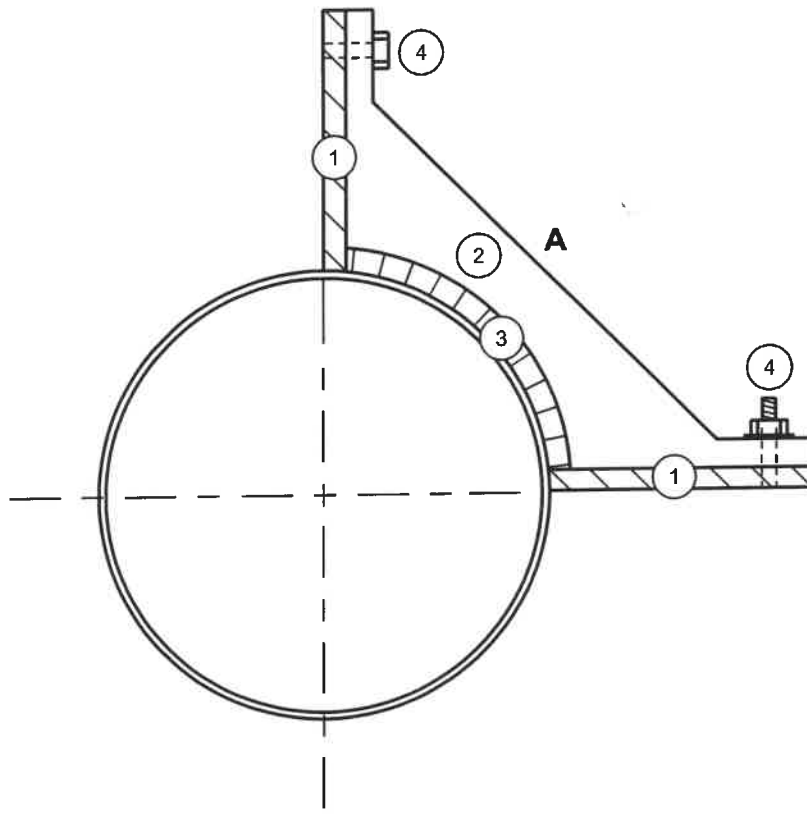

NO.	ASSESSMENT CRITERIA	MARK
1	Vertical boards	2
2	Yoke/Collar	1
3	Laggings	1
4	Bolts and nuts	2
<b>TOTAL:</b>		<b>6</b>

(6)

DEPARTMENT OF BASIC EDUCATION  
CENTRAL PROVINCE  
PRIVAT BAG X935, PRETORIA 0001  
  
2023 -11- 29  
  
APPROVED MARKING GUIDELINE  
PUPILS EXAMINATION

*(Handwritten signatures)*

5.5

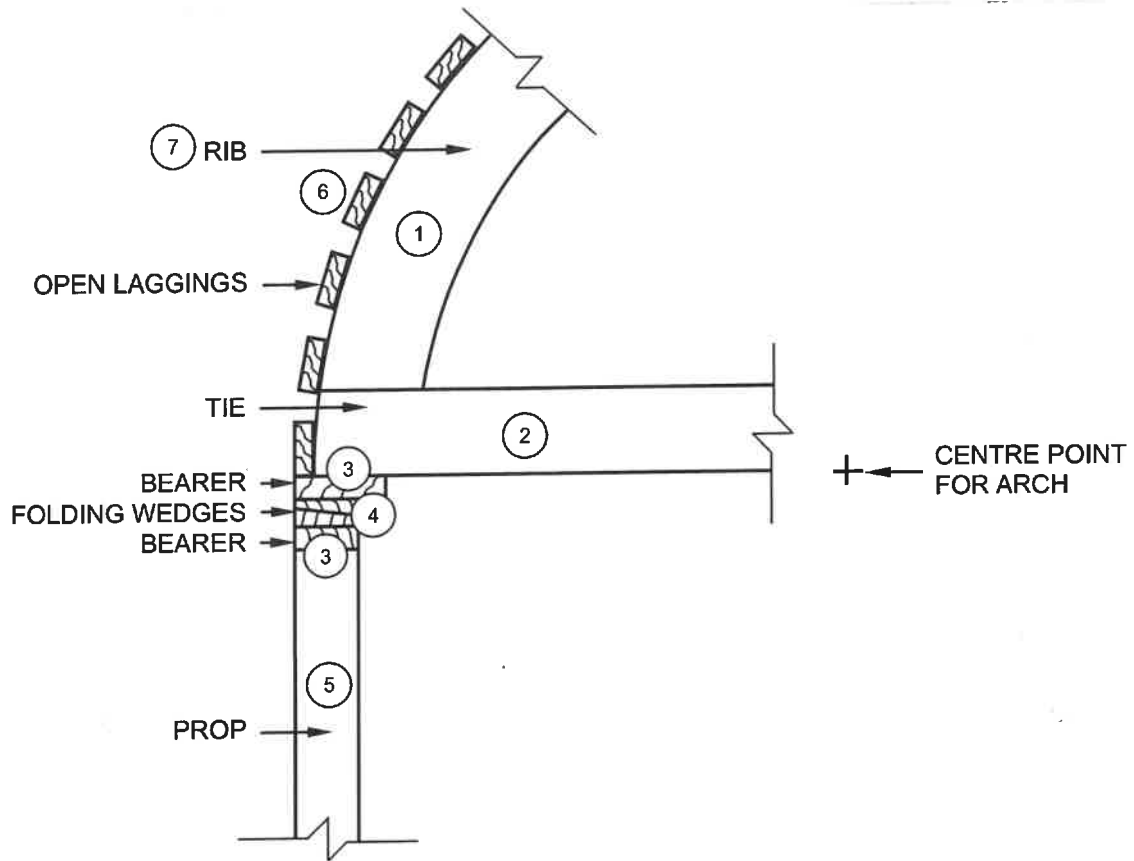

NO.	ASSESSMENT CRITERIA	MARK
1	Rib	1
2	Tie	1
3	Bearer above wedges	1
	Bearer below wedges	1
4	Folding wedges (Must be a pair of wedges)	1
5	Prop	1
6	Open laggings (Minimum of two laggings showing opening)	1
7	Any ONE label	1
<b>TOTAL:</b>		<b>8</b>

(8)

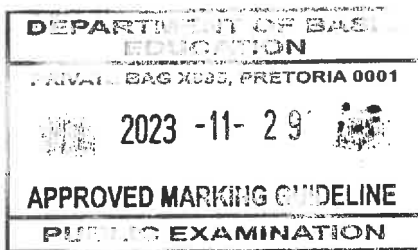

*(Handwritten initials)*

*(Handwritten signature)*



5.6

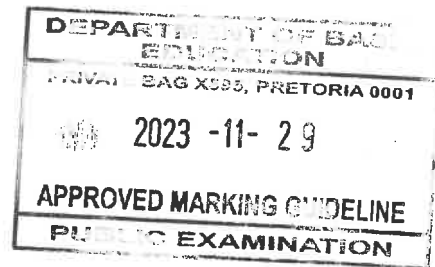
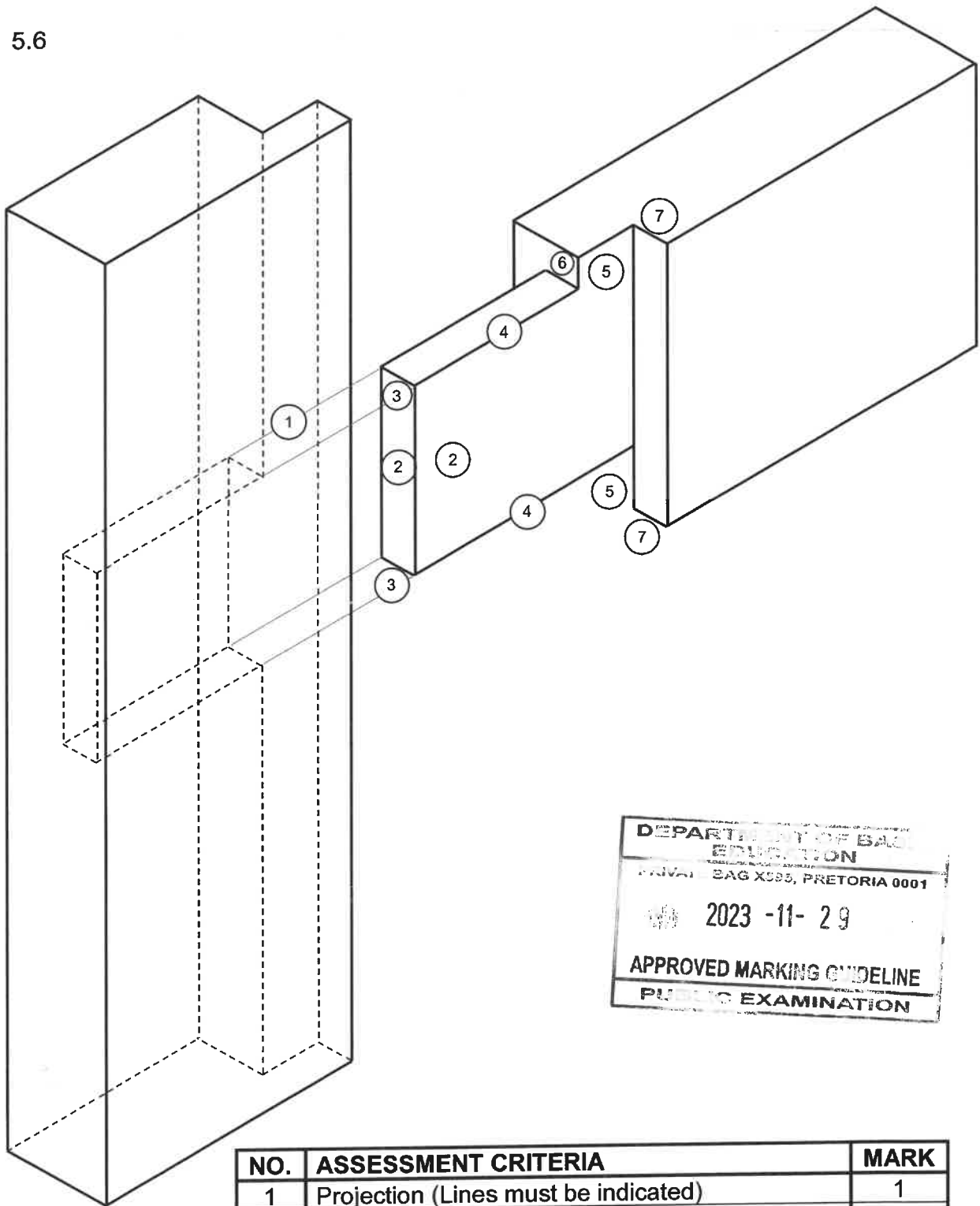

NO.	ASSESSMENT CRITERIA	MARK
1	Projection (Lines must be indicated)	1
2	Height of tenon (1 x front + 1 x side)	2
3	Width of tenon (1 x top + 1 x bottom)	2
4	Length of tenon (1 x short top + 1 x long bottom)	2
5	Rebate (1 x top + 1 x bottom)	2
6	Short shoulder	1
7	Long shoulder (1 x top + 1 x bottom)	2
<b>TOTAL:</b>		<b>12</b>

(12)  
[30]

**QUESTION 6: SUSPENDED FLOORS, STAIRCASES, IRONMONGERY, DOORS AND JOINING (SPECIFIC)**

6.1 Ways to install locks:

- Fixed onto the surface ✓
- Mortised into door stiles ✓
- Recessed into doors

**ANY TWO OF THE ABOVE**

(2)

6.2

6.2.1

Marking of the tenon for a joint:

- A - Mark the length of the joint ✓
- B - Mark out the width of the tenon/Mark out the tenon by dividing B the thickness of the wood into three equal parts ✓
- C - Set out the length/height of the tenon ✓
- D - Mark out the double tenon ✓

(4)

6.2.2

Cutting the tenon for a joint:

**NOTE: Cutting order as indicated may differ.**

- Using a tenon saw, cut along the length of the joint on both sides of the tenon ✓
- Saw the shoulders along the sides of the cheeks ✓
- Crosscut along the shoulder line on both sides of the wood ✓
- Crosscut the double tenon up to the shoulder of the joint ✓

(4)

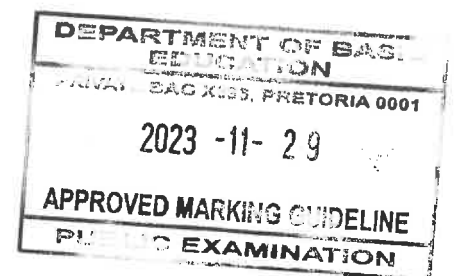

6.3

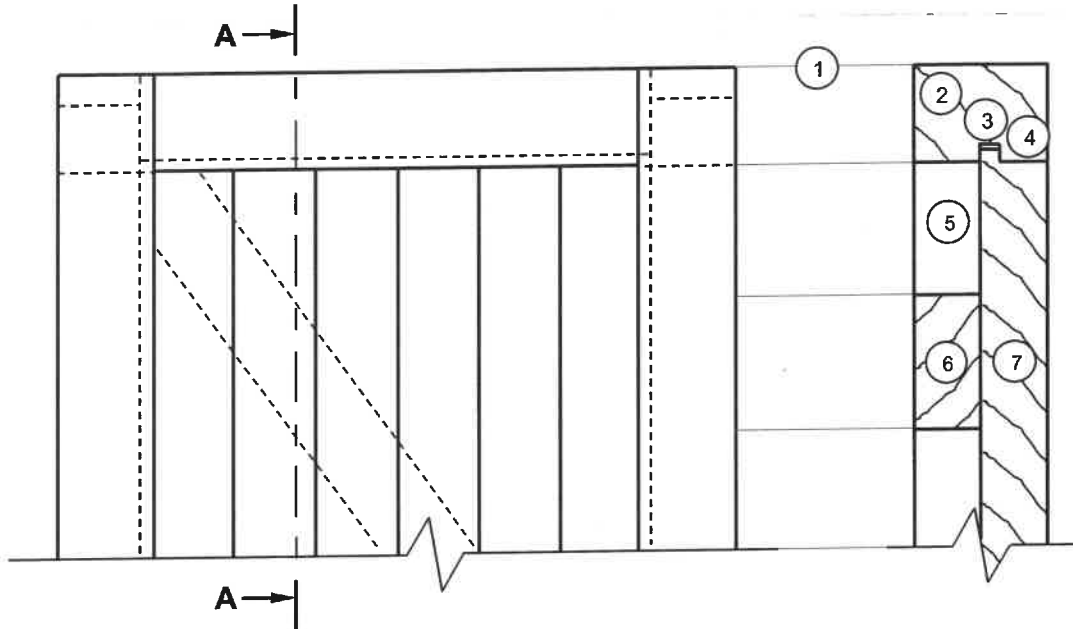

NO.	ASSESSMENT CRITERIA	MARK
1	Projection (Lines must be indicated)	1
2	Top rail	1
3	Clearance/Opening	1
4	Rebated tongue	1
5	Hanging stile/Stile	1
6	Brace	1
7	V-Tong-and-groove-batten	1
<b>TOTAL:</b>		<b>7</b>

(7)

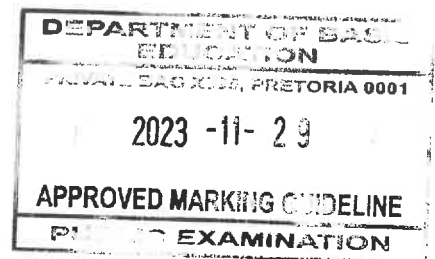

*(Handwritten initials)*

*(Handwritten signature)*

6.4

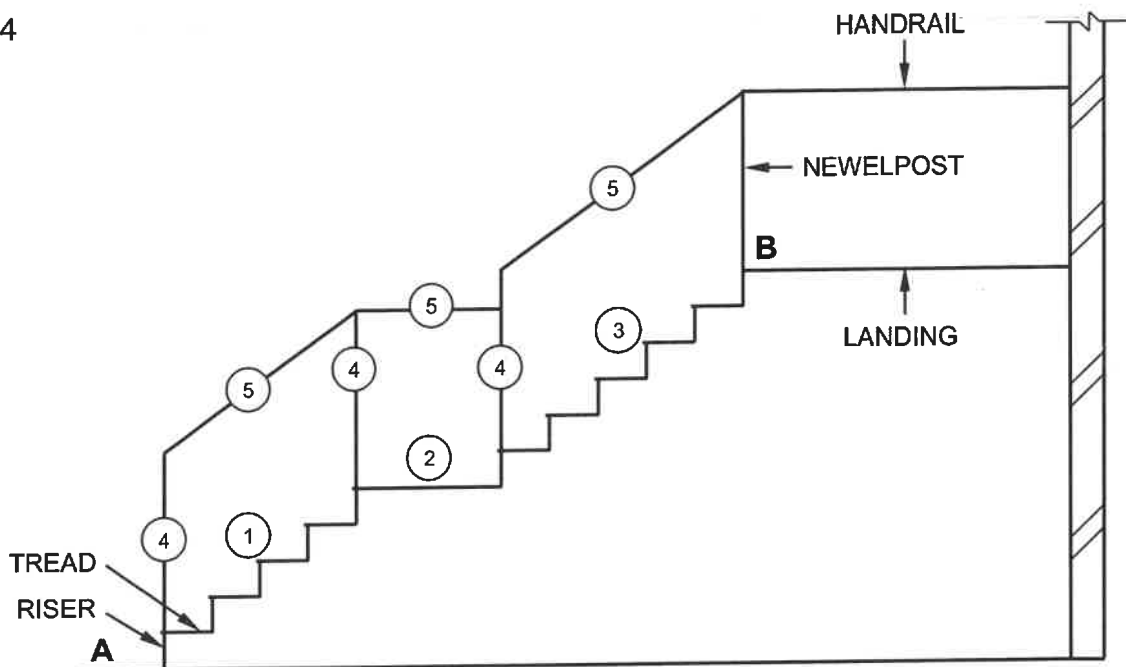

NO.	ASSESSMENT CRITERIA	MARK
1	Flight of stairs (Four steps)	1
2	Landing	1
3	Flight of stairs (Five steps)	1
4	Newel posts	3
5	Handrails	3
<b>TOTAL:</b>		<b>9</b>

(9)

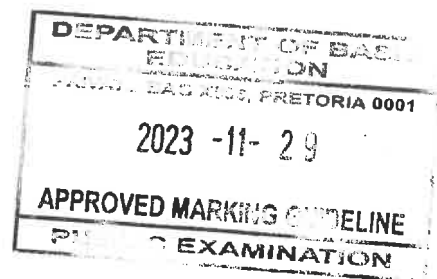

6.5

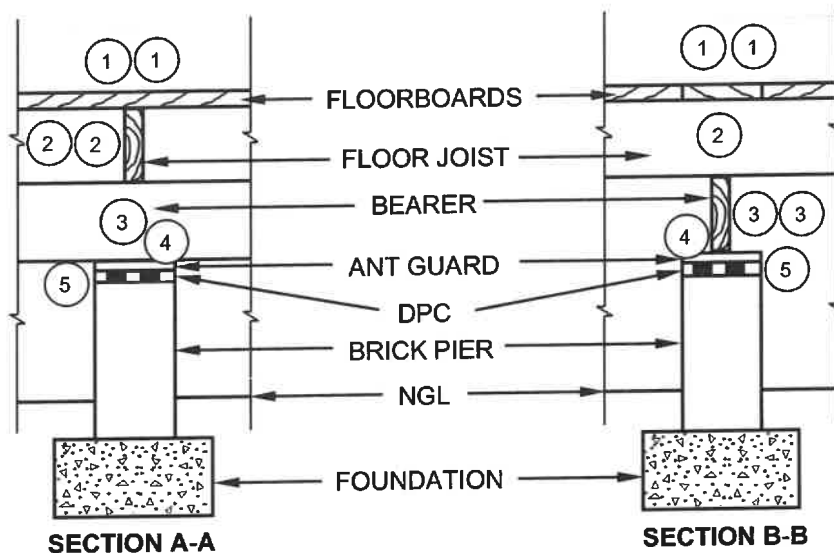

NO.	ASSESSMENT CRITERIA	MARK
1	Floorboards with hatching (Section A-A solid) (Section B-B at least two boards)	4
2	Floor joists and hatching on section A-A	3
3	Bearers and hatching on section B-B	3
4	Ant guard	2
5	Damp-proof course	2
<b>TOTAL:</b>		<b>14</b>

(14)  
[40]

**TOTAL: 200**

