



# basic education

Department:  
Basic Education  
**REPUBLIC OF SOUTH AFRICA**

**NATIONAL  
SENIOR CERTIFICATE**

**GRADE 12**

**MCTA.1**

**MECHANICAL TECHNOLOGY: AUTOMOTIVE**

**NOVEMBER 2021**

**MARKS: 200**

**TIME: 3 hours**

This question paper consists of 17 pages and a 2-page formula sheet.

# AFTERNOON SESSION



**INSTRUCTIONS AND INFORMATION**

1. Write your centre number and examination number in the space provided on the ANSWER BOOK.
2. Read ALL the questions carefully.
3. Answer ALL the questions.
4. Number the answers correctly according to the numbering system used in this question paper.
5. Start EACH question on a NEW page.
6. Show ALL calculations and units. Round off final answers to TWO decimal places.
7. Candidates may use non-programmable scientific calculators and drawing instruments.
8. The value of gravitational acceleration should be taken as  $10 \text{ m/s}^2$ .
9. All dimensions are in millimetres, unless stated otherwise in the question.
10. Write neatly and legibly.
11. A formula sheet is attached at the end of the question paper.
12. Use the criteria below to assist you in managing your time.

QUESTION	CONTENT	MARKS	TIME IN MINUTES
<b>GENERIC</b>			
1	Multiple-choice questions	6	6
2	Safety	10	10
3	Materials	14	14
<b>SPECIFIC</b>			
4	Multiple-choice questions	14	10
5	Tools and Equipment	23	20
6	Engines	28	25
7	Forces	32	25
8	Maintenance	23	20
9	Systems and Control (Automatic Gearbox)	18	20
10	Systems and Control (Axles, Steering Geometry and Electronics)	32	30
<b>TOTAL</b>		<b>200</b>	<b>180</b>



**QUESTION 1: MULTIPLE-CHOICE QUESTIONS (GENERIC)**

Various options are provided as possible answers to the following questions. Choose the answer and write only the letter (A–D) next to the question numbers (1.1 to 1.6) in your ANSWER BOOK, e.g. 1.7 E.

- 1.1 What is the code of good practice for HIV/Aids and employment?
- A Persons with HIV/Aids must use separate dining halls.
  - B The Act contains common guidelines on how employers and employees should respond to HIV/Aids in the workplace.
  - C The Act contains guidelines on how much work an employee is supposed to do.
  - D It contains the daily working hours of employees. (1)
- 1.2 Which ONE of the following types of personal protective equipment (PPE) is required when working in a workshop with Covid-19 regulations?
- A Mask
  - B Sunglasses
  - C Welding helmet
  - D Clear goggles (1)
- 1.3 The ... is responsible for the provision of safety gear in the workshop.
- A employees
  - B cleaning staff
  - C foreman
  - D employer (1)
- 1.4 Which ONE of the following describes the reaction of mild steel when it is cut on a machine?
- A Cuts easily; black crumbly chips
  - B Hard to cut; cuttings break in sharp chips
  - C Cuts easily; curly chips
  - D Hard to cut (1)
- 1.5 The purpose of hardening steel is to ...
- A resist wear.
  - B relieve strain.
  - C increase softness.
  - D quench the material. (1)
- 1.6 Which process follows on from hardening?
- A Normalising
  - B Annealing
  - C Tempering
  - D Case hardening (1)

**[6]**

**QUESTION 2: SAFETY (GENERIC)**

- 2.1 Explain TWO first-aid measures to consider when treating an open wound. (2)
- 2.2 State TWO safety precautions that must be adhered to after the surface grinder has been switched on. (2)
- 2.3 Give ONE reason why the pressure gauge of a hydraulic press must be calibrated frequently. (1)
- 2.4 Which TWO hazards are prevented by the finger protectors fitted to power-driven guillotines? (2)
- 2.5 State TWO safety measures to be considered before gas welding or flame cutting operations can be performed. (2)
- 2.6 Which type of workshop layout is shown in FIGURE 2.6 below? (1)

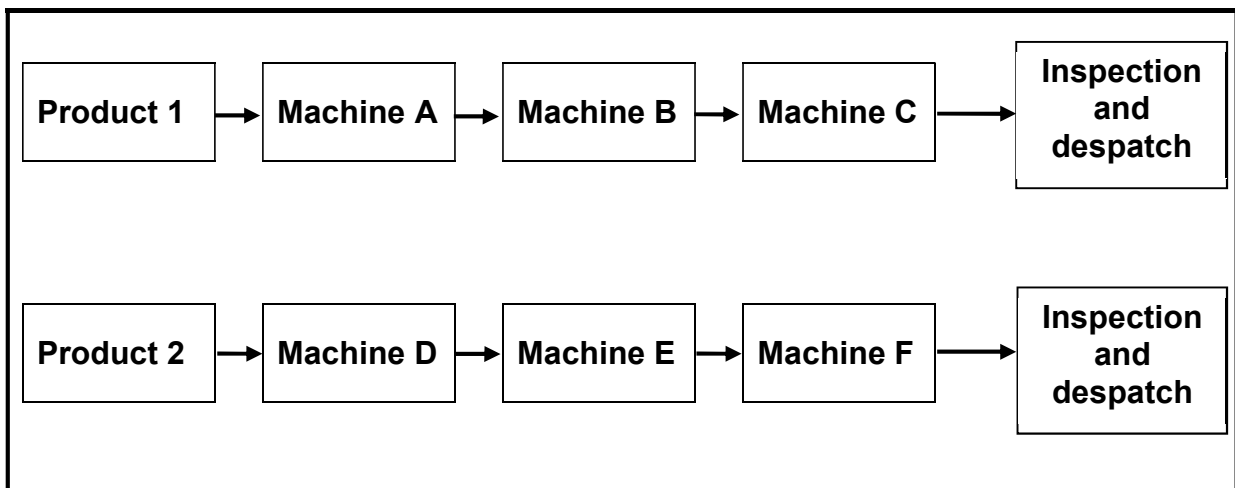

**FIGURE 2.6**

(1)  
[10]



**QUESTION 3: MATERIALS (GENERIC)**

3.1 Describe the filing process as easy or difficult when conducting a file test for hardness on the following materials:

3.1.1 Cast steel (1)

3.1.2 Mild steel (1)

3.1.3 High-speed steel (1)

3.2 FIGURE 3.2 below shows the annealing process during heat treatment. Label components **A–C**.

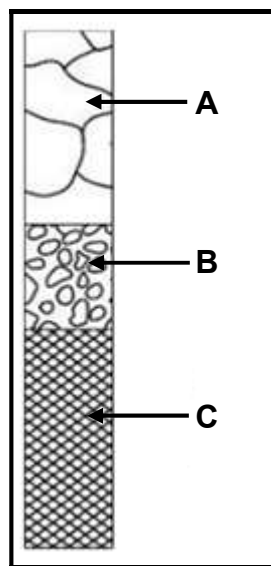

**FIGURE 3.2**

(3)

3.3 Describe how a bending test is conducted to determine the properties in a test metal. (3)

3.4 State the purpose of case hardening of steel. (2)

3.5 Name THREE types of quenching media that could be used to harden steel. (3)

**[14]**



**QUESTION 4: MULTIPLE-CHOICE QUESTIONS (SPECIFIC)**

Various options are provided as possible answers to the following questions. Choose the answer and write the letter (A–D) next to the question numbers (4.1 to 4.14) in the ANSWER BOOK, e.g. 4.15 E.

- 4.1 Which type of balancing is performed at high speeds?
- A Normal balancing
  - B Static balancing
  - C Dynamic balancing
  - D Vibrational balancing
- (1)
- 4.2 What is the function of the turn-table while performing wheel alignment checks?
- A To statically balance the wheel
  - B Allows the wheels to turn in and out with minimal resistance
  - C To determine the amount of friction between the wheel and the wheel bearing
  - D To dynamically balance the wheel
- (1)
- 4.3 The camshaft rotation for the ignition of the air and fuel mixture in a four-stroke four-cylinder engine, occurs every ... degrees.
- A 180
  - B 120
  - C 90
  - D 60
- (1)
- 4.4 Which forced induction system has the most lag?
- A Non-variable type turbocharger
  - B Variable geometry turbocharger
  - C Supercharger
  - D Twin-charging
- (1)
- 4.5 The compression ratio (CR) of an engine is the relationship between the ...
- A total volume of the engine and the volume of one cylinder.
  - B total volume of a cylinder and the clearance volume.
  - C compression pressure and the atmospheric pressure.
  - D swept volume and the clearance volume.
- (1)



- 4.6 Indicated power can be defined as the ...
- A power measured at the wheels by a dynamometer.
  - B power measured at the flywheel by a Pröny brake.
  - C measure to determine the power developed at the flywheel.
  - D measure to determine the power developed by the burning fuel within the cylinder of an engine. (1)
- 4.7 A dynamometer measures the ...
- A theoretical power developed by the engine.
  - B brake power of the engine.
  - C electrical power developed by the engine.
  - D theoretical torque developed by the engine. (1)
- 4.8 Which of the following is the cause of high levels of hydrocarbon (HC) in the exhaust gases of an internal combustion engine?
- A Too lean mixture
  - B Excessive boost pressure
  - C Leak at the throttle body
  - D Dirty or restricted air filter (1)
- 4.9 What will cause a high oil pressure reading in an internal combustion engine?
- A Defective oil pressure relief valve
  - B Insufficient oil in the system
  - C Oil leaks
  - D Viscosity of the oil is too thin (1)
- 4.10 Which component in an automatic gearbox directs the oil pressure to select the required gear ratio?
- A Brake bands
  - B Torque converter
  - C Control valve body
  - D Oil pump (1)
- 4.11 How is the lock-up clutch activated in a torque converter?
- A By oil pressure
  - B Using the clutch pedal
  - C Pressing an activation switch
  - D Automatically by the stator (1)



4.12 What is the cause of the tyre wear indicated in FIGURE 4.12 below?

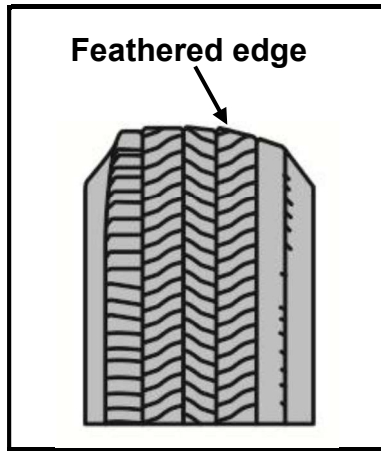

**FIGURE 4.12**

- A Excessive camber
- B Incorrect castor
- C Unbalanced wheel
- D Excessive toe-in or toe-out (1)

4.13 Wheel alignment is performed on a motor vehicle to achieve ...

- A wheel spin when racing.
- B over-steering.
- C poor wheel tracking.
- D even tyre wear. (1)

4.14 The function of a sensor in an engine-management system is to ...

- A activate an engine system.
  - B detect engine operating conditions.
  - C determine the air-fuel mixture.
  - D regulate the fuel pressure. (1)
- [14]**





**QUESTION 5: TOOLS AND EQUIPMENT (SPECIFIC)**

5.1 The steps to conduct a compression test on an internal combustion engine are listed below. Complete STEPS 5 to 8.

**NOTE:** Number your answers 5.1.1 to 5.1.4 as shown.

STEP 1 Ensure the engine is at operating temperature.

STEP 2 Disconnect the fuel supply and ignition system.

STEP 3 Clean the area around the spark plugs and remove all spark plugs.

STEP 4 Connect a compression tester to the spark plug hole.

STEP 5 5.1.1 (1)

STEP 6 5.1.2 (1)

STEP 7 5.1.3 (1)

STEP 8 5.1.4 (1)

5.2 Answer the questions related to the cylinder leakage tester shown in FIGURE 5.2 below.

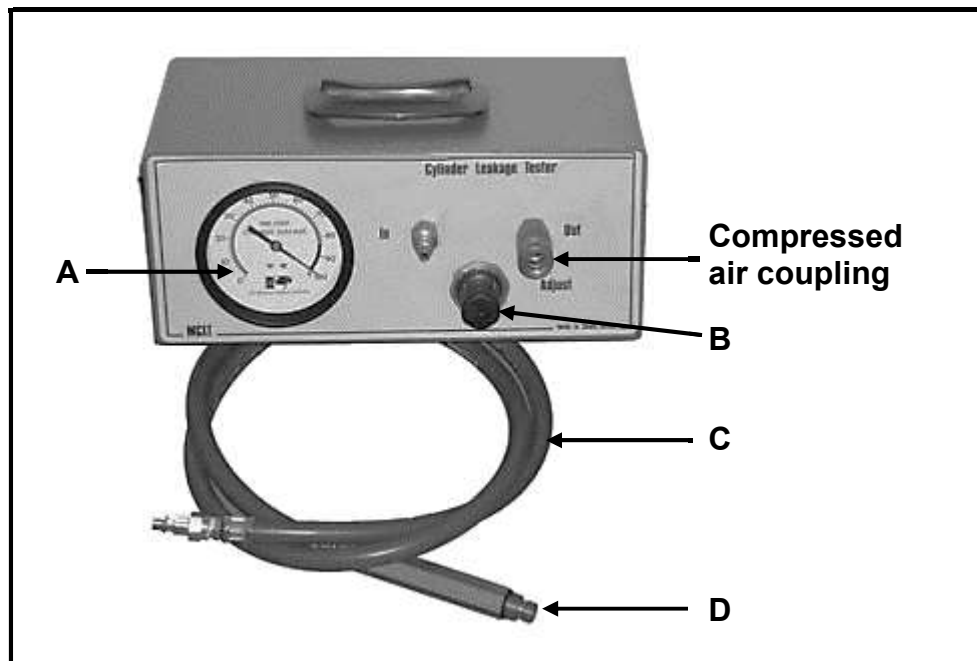

**FIGURE 5.2**

5.2.1 Label parts **A–D** in FIGURE 5.2 above. (4)

5.2.2 What is the unit of measure on component **A**? (1)

- 5.3 Name TWO components that protect the exhaust gas analyser against soot and moisture when performing the exhaust gas analysing test. (2)
- 5.4 Describe the set-up procedure of an on-board diagnostics (OBD) scanner to check for faults. (3)
- 5.5 FIGURE 5.5 below shows a machine used in an automotive workshop. Answer the questions that follow.

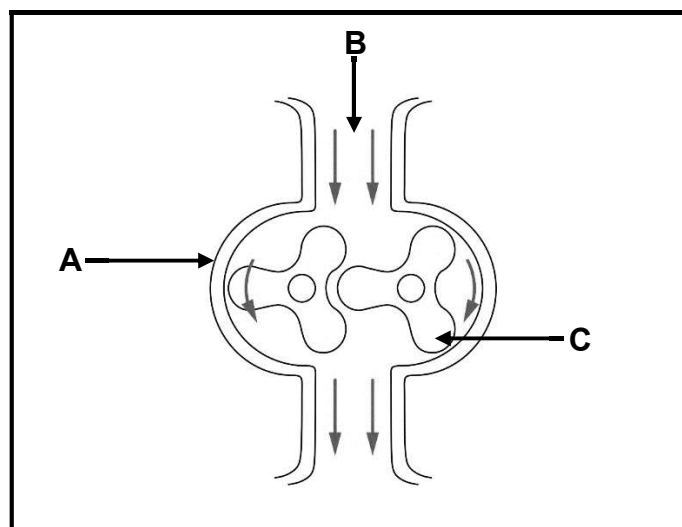

**FIGURE 5.5**

- 5.5.1 Identify the machine shown in FIGURE 5.5 above. (1)
- 5.5.2 What is the function of the machine shown in FIGURE 5.5 above? (1)
- 5.5.3 Which safety feature is not present on the machine in FIGURE 5.5 above? (1)
- 5.6 Which THREE wheel alignment angles can be measured using the bubble gauge? (3)
- 5.7 State THREE precautions to be taken before the optical wheel alignment equipment is fitted to the wheel. (3)
- [23]**

**QUESTION 6: ENGINES (SPECIFIC)**

- 6.1 With reference to the crankshaft, give THREE reasons for using the correct firing order on an internal combustion engine. (3)
- 6.2 State TWO ways in which dynamic imbalance of the crankshaft can be corrected. (2)
- 6.3 State FOUR causes of engine vibration. (4)
- 6.4 Give the degrees of crankshaft rotation between power impulses for each of the following four-stroke engines:
  - 6.4.1 4-cylinder (1)
  - 6.4.2 5-cylinder (1)
  - 6.4.3 6-cylinder (1)
  - 6.4.4 8-cylinder (1)
- 6.5 FIGURE 6.5 below shows a Roots supercharger. Answer the questions that follow.



**FIGURE 6.5**

- 6.5.1 Label components **A–C** in FIGURE 6.5 above. (3)
- 6.5.2 Describe the operation of the Roots supercharger. (5)
- 6.6 What is the function of the following components on an internal combustion engine equipped with a variable geometry turbocharger?
  - 6.6.1 Intercooler (2)
  - 6.6.2 Vanes (2)
- 6.7 State THREE advantages of a *supercharger* when compared to a *turbocharger*. (3)

**[28]**



**QUESTION 7: FORCES (SPECIFIC)**

7.1 Define the following terms regarding an internal combustion engine:

7.1.1 Brake power (2)

7.1.2 Torque (2)

7.2 The indicated power diagram represents the power stroke and compression stroke. How do the compression stroke and power stroke affect the pressure? (2)

7.3 FIGURE 7.3 below shows a cylinder with the piston at TDC and the same cylinder with the piston at BDC. The following information is applicable:

Volume ( $V_1$ ) of the space when the piston is at TDC =  $39 \text{ cm}^3$

Space between TDC and BDC ( $V_2$ ) = 330 ml

Distance between TDC and BDC is 65 mm

Answer the questions that follow.

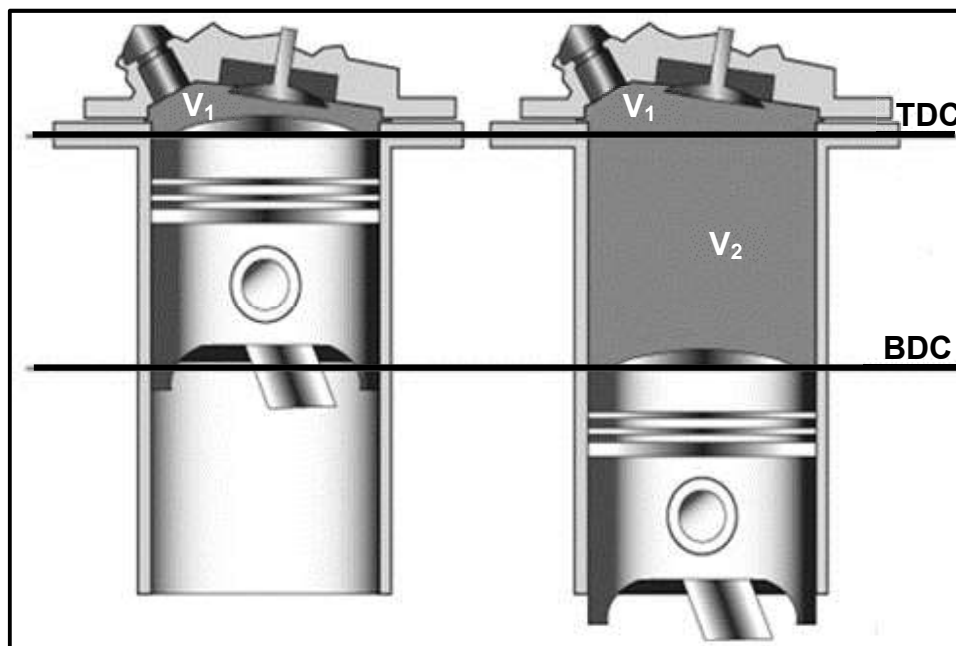

**FIGURE 7.3**

7.3.1 Which term is used to describe the volume  $V_1$ ? (1)

7.3.2 Which term is used to describe the volume  $V_2$ ? (1)

7.3.3 Calculate the total cylinder volume in  $\text{cm}^3$ . (3)

7.3.4 Calculate the bore diameter in mm. (5)

7.3.5 Calculate the compression ratio of this cylinder. (2)

7.4 State TWO methods to lower the compression ratio in an internal combustion engine. (2)

7.5 The following data refers to a two-cylinder two-stroke petrol engine:

Engine speed during test:	6 500 r/min
Cylinder displacement (volume):	580,7 cm <sup>3</sup>
Mean effective pressure:	450 kPa
Brake power:	48 kW @ 6 500 r/min

Determine the following by means of calculations:

- 7.5.1 Torque (4)
- 7.5.2 Indicated power in kW (6)
- 7.5.3 Mechanical efficiency (2)
- [32]**



**QUESTION 8: MAINTENANCE (SPECIFIC)**

- 8.1 Answer the following questions with reference to an exhaust gas analysis.
  - 8.1.1 State TWO causes of a low CO<sub>2</sub> exhaust gas reading. (2)
  - 8.1.2 State TWO corrective measures for the causes stated in QUESTION 8.1.1. (2)
- 8.2 State TWO exhaust gas readings, as detected by a gas analyser, which are caused by a lean air/fuel mixture. (2)
- 8.3 State ONE cause and ONE corrective measure for the following cylinder leakage test results:
  - 8.3.1 Hissing sound at the exhaust pipe (2)
  - 8.3.2 Bubbles in the radiator water (2)
- 8.4 Explain why an internal combustion engine should be at normal operating temperature when diagnostic tests are performed. (2)
- 8.5 The table below shows possible causes and corrective measures for low fuel pressure in a motor vehicle. Complete the table below by writing only the question numbers (8.5.1 to 8.5.4) and the answer in the ANSWER BOOK.

POSSIBLE CAUSES	CORRECTIVE MEASURES
Faulty fuel pump	Test and replace fuel pump
Blocked or restricted fuel filter	8.5.1
8.5.2	Renew or disconnect and blow out fuel lines
Clogged pump inlet strainer	8.5.3
8.5.4	Check and correct the voltage to the pump

- 8.6 State THREE manufacturer’s specifications required before an oil pressure test can be done. (3)
  - 8.7 Explain FOUR steps to perform a radiator cap pressure test. (4)
- [23]**



**QUESTION 9: SYSTEMS AND CONTROL (AUTOMATIC GEARBOX) (SPECIFIC)**

9.1 FIGURE 9.1 below shows a torque converter used in automatic transmissions. Answer the questions that follow.

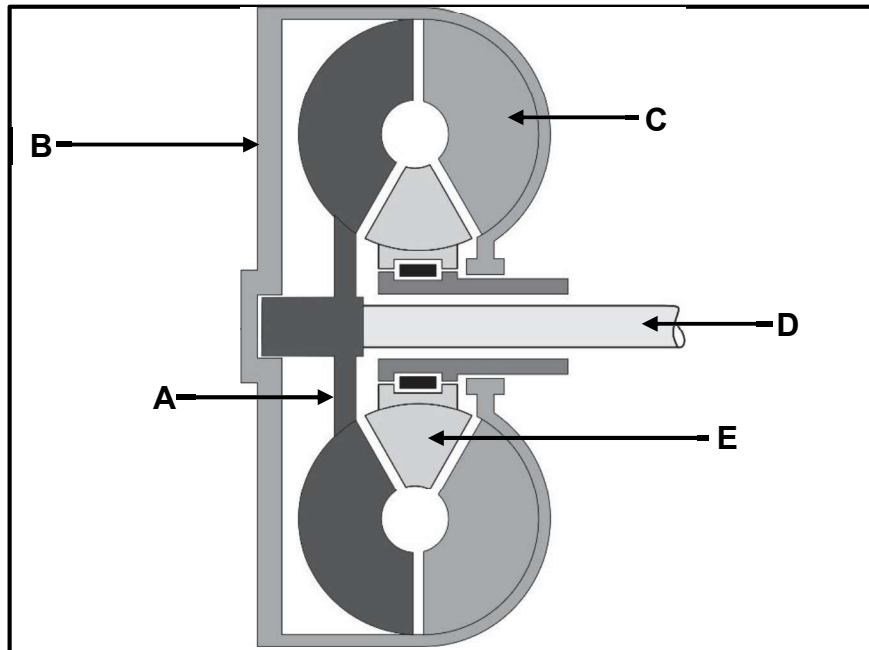

**FIGURE 9.1**

9.1.1 Label parts **A–E** in FIGURE 9.1 above. (5)

9.1.2 State THREE functions of a torque converter. (3)

9.1.3 When is maximum torque multiplication obtained in a torque converter? (2)

9.2 Explain how forward overdrive is obtained in an epicyclic gear train. (3)

9.3 What do the following gearshift lever positions on an automatic transmission refer to?

9.3.1  (1)

9.3.2  (1)

9.3.3  (1)

9.4 In which TWO gearshift lever positions, *P*, *R*, *N*, *D*, *1* or *2*, is it possible to start the engine fitted with an automatic transmission? (2)

**[18]**



**QUESTION 10: SYSTEMS AND CONTROL (AXLES, STEERING GEOMETRY AND ELECTRONICS) (SPECIFIC)**

- 10.1 Give THREE reasons why wheel alignment must be done on a vehicle. (3)
- 10.2 FIGURE 10.2 below shows camber wear on a tyre. Answer the questions that follow.

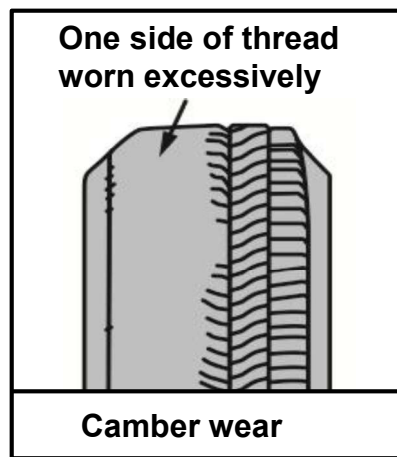
**FIGURE 10.2**

- 10.2.1 State FOUR causes of excessive camber wear. (4)
- 10.2.2 Define *positive camber angle*. (2)
- 10.2.3 How is camber adjusted on a suspension? (2)
- 10.3 Draw a neat, labelled sketch to show toe-in on a vehicle's front wheels. (3)
- 10.4 State TWO negative effects caused by dynamic imbalances on a wheel. (2)
- 10.5 Name TWO types of electronic injectors. (2)
- 10.6 Describe the purpose of a diesel particulate filter (DPF). (2)
- 10.7 Explain how the headway sensor operates in an adaptive speed control system. (2)



10.8 FIGURE 10.8 below shows a component of an alternator. Answer the questions that follow.

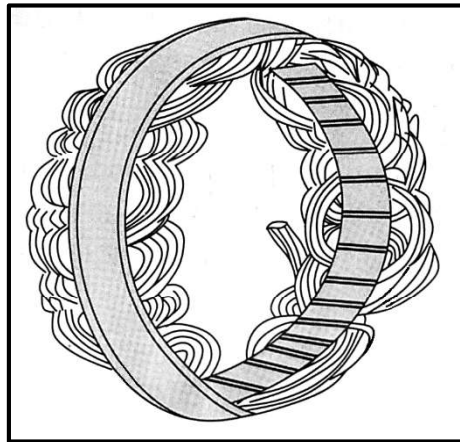

**FIGURE 10.8**

- 10.8.1 Identify the component in FIGURE 10.8 above. (1)
- 10.8.2 What is the function of the component shown in FIGURE 10.8 above? (2)
- 10.8.3 Draw TWO labelled sketches to show the two types of windings for the component in FIGURE 10.8. (4)

10.9 State THREE advantages of an electric fuel pump fitted to an internal combustion engine. (3)  
**[32]**

**TOTAL: 200**



**FORMULA SHEET FOR MECHANICAL TECHNOLOGY: AUTOMOTIVE**

1.  $F = m \times a$

Where:

m = mass

a = acceleration

2. Work done = Force  $\times$  Displacement      OR       $W = F \times s$

3.  $\text{Power} = \frac{\text{Force} \times \text{Displacement}}{\text{Time}}$       OR       $P = \frac{F \times s}{t}$

4. Torque = Force  $\times$  Radius      OR       $T = F \times r$

5.  $IP = P \times L \times A \times N \times n$

Where:

IP = Indicated power

P = Mean effective pressure

L = Stroke length

A = Area of piston crown

N = Number of power strokes per second

n = Number of cylinders

6.  $BP = 2 \pi NT$

Where:

BP = Brake power

N = Revolutions per second

T = Torque

7. Brake power with Prony brake =  $2 \times \pi \times N \times F \times R$

Where:

BP = Brake power

N = Revolutions per second

F = Force

R = Brake arm length



8. Mechanical efficiency =  $\frac{BP}{IP} \times 100\%$

9. Compression ratio =  $\frac{SV + CV}{CV}$

Where:

SV = Swept volume

CV = Clearance volume

10.  $SV = \frac{\pi D^2}{4} \times L$

Where:

D = Bore diameter

L = Stroke length

11.  $CV = \frac{SV}{CR-1}$

12. Gear ratio =  $\frac{\text{Product of teeth on driven gears}}{\text{Product of teeth on driver gears}}$